



EB0637

Training and  
Trellising Grapes  
for Production  
in Washington

# Contents



Different Grape Types

Trellis Systems

New Systems of Trellising

End Posts and Anchorage

Spacing and Vineyard Layout

Training and Pruning Young vines

Training European Varieties for Winter Protection

Summary and Glossary

# Training and Trellising Grapes for Production in Washington



by M. Ahmedullah, Ph.D., Associate Horticulturist,  
Washington State University, Pullman

This bulletin provides information on training and trellising systems in commercial use in Washington. Other systems not in commercial use which have been tried on a small scale by growers or experiment stations are also discussed. Mention of some of the newer systems does not mean that they are recommended to the growers.

## Different Grape Types

Two types of grapes are grown commercially in Washington state:

- 1) American grapes, *Vitis labrusca* and
- 2) European grapes *Vitis vinifera*. American grapes represented by the cultivar Concord are used primarily for juice making.

A small acreage supports the variety Niagara, a white labrusca type. Eleven cultivars of vinifera grapes are used exclusively for making wine. Another small acreage grows European type table grapes, which are harvested by hand. Almost all labrusca grapes are mechanically harvested. Many vinifera types also are harvested mechanically. Take mechanical harvesting into consideration when designing trellising and training systems for grapes.

The grapevine does not have a rigid trunk; therefore, some support structure, usually a trellis, must be

provided. The trellis design should provide maximum light penetration for the buds and clusters, especially in the later part of the growing season, while exposing a large percentage of the leaves to sunlight. The grape trellis is a major long-term investment. Before designing a trellis, growers must consider all those factors that may affect vine growth and management, e.g., irrigation systems, variety, vine vigor, mechanical pruning, and mechanical harvesting.

A good trellis should have some or most of the following characteristics:

- 1) strong and long-lived;
- 2) supports the trunk, cordons, arms, spur, canes, and foliage;
- 3) provides the maximum exposure of leaves and buds to sunlight;
- 4) economical to construct;
- 5) easy to repair and maintain;
- 6) permanent with little need for annual maintenance; and
- 7) adaptable to modern mechanical pruning and harvesting machines.

Several kinds of trellises and training systems are in use in Washington. Growers are trying new ones. Primary differences among these are in height, number and location of wires, use of horizontal wire spreaders, flexible extended arms, posts for support of wires, end posts, and anchorage for end posts.

# Trellis Systems

## Single wire system

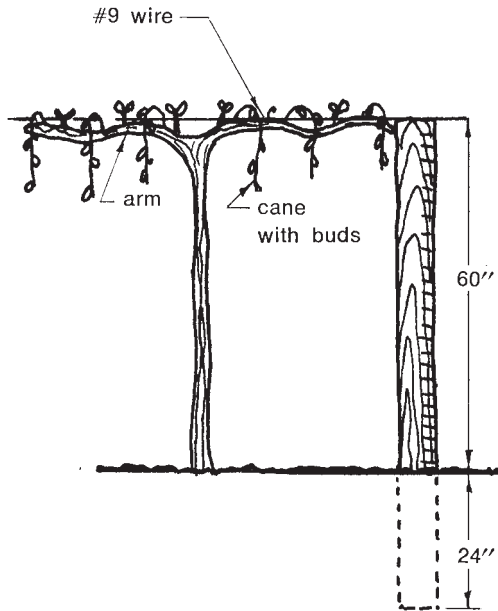

Figure 1. Single wire system.

Seven-foot posts having a minimum top diameter of 3 to 4 inches are spaced about 18 to 21 feet apart (every three plants). Line posts must be buried at least 2 feet in the ground for adequate support. A single #9 wire is then placed across the top of the post, 5 feet above the ground (Figure 1). Grapes are cordon trained along this wire in both directions. They also can be cane pruned but this is not common in Washington.

This system is least expensive of all trellising systems. It is adapted to mechanical harvesting, and is used for Concord grapes. It does not offer full exposure of foliage to sunlight for vigorous varieties.

## Two-wire vertical trellis

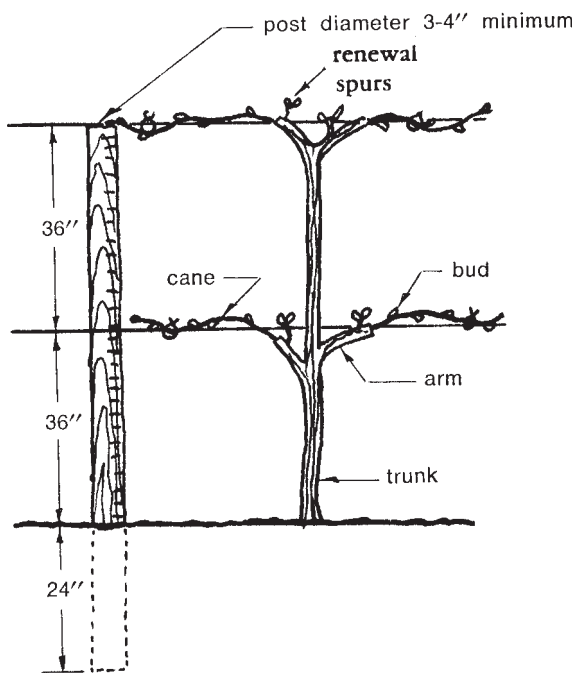

Figure 2. Two-wire vertical trellis, vines bilateral cordon trained.

The line posts have a top diameter of 3 to 4 inches. They are 7 feet long, placed 18 to 21 feet apart. As in the single wire system, the line posts should extend at least 2 feet into the ground. The top wire is placed across the top of the post with the second wire placed 30 to 36 inches lower (Figure 2). The height of the second wire should not be so low that fruit cannot be picked during mechanical harvesting. The vines are bilateral cordon trained on the top wire. The bottom wire is used for training two canes on either side of the trunk. This system, sometimes known as the Kniffin system, is used for Concord grapes in Washington.

A two-wire vertical trellis system is commonly used for vinifera grapes. Put the top wire on top of the post 5 feet above ground level. This is referred to as the foliage wire. Number 11 wire is used for foliage wire. For cordon support, place a second wire (#9 wire) 16 inches below the top wire and 44 inches above ground level.

## Two-wire multiple trunk system

This system is not practiced commercially today because of the extra expense involved. However, some interest exists in this system because of severe winter damage to vinifera grapes in less desirable sites. Instead of a single trunk, multiple trunks are allowed to develop for vinifera grapes. The arms and canes are removed from the trellis each fall and covered with soil for winter protection (Figure 2a). In this kind of training five canes serve as flexible trunks. The trunks are tied up on the wire for support. Earlier plantings of vinifera grapes were started with this system.

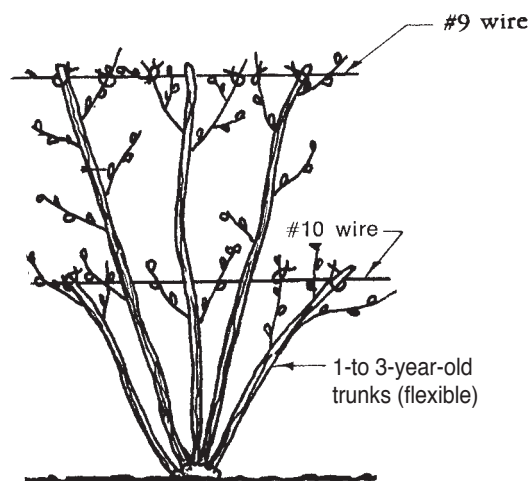

**Figure 2a. Multiple trunk (Fan) training of vinifera cultivars on a two-wire vertical trellis.**

## “T” Trellis

The wires of the “T” trellis are parallel. They are separated and supported by a crossarm attached to the post. This provides for better use of sunlight. In this three-wire system, the center wire is located on the 8-foot line posts approximately 5 feet above the surface of the ground. A 3-to 4-foot wooden or metal crossarm is attached across the top of the post (6 feet above the ground). The two parallel wires attach to each end of the crossarm to support the fruiting canes. A #12 wire is used for the center and two #9 wires are used at each end of the crossarm (Figure 3). Given the use of mechanical harvesters for vinifera grapes, the use of a metal crossarm is becoming very popular.

The principal advantage of the “T” trellis is greater exposure of foliage to sunlight. The disadvantage has been the difficulty of adapting this system to mechanical harvesting. Where proper adjustments are made in harvesting machines, however, this system has been well adapted by many growers. It can be used both for Concord and vinifera grapes. The cost of installation is higher than the single wire and two-wire vertical systems.

For vinifera grapes, place the lower or main wire 4½ feet (54 inches) above the ground to carry the main arms of the vine. Place the 2-foot-long crossarm even with the top of the post, 6 feet above the ground. Three wires are positioned on this crossarm. Since their purpose is to support only the nonfruiting growth, they can be #12 wires. Wires are placed on the ends of the 2-foot crossarm and a third wire attached to the top of the line posts. This latter wire prevents young shoots from being blown by the wind on one side of the trellis during their early growth.

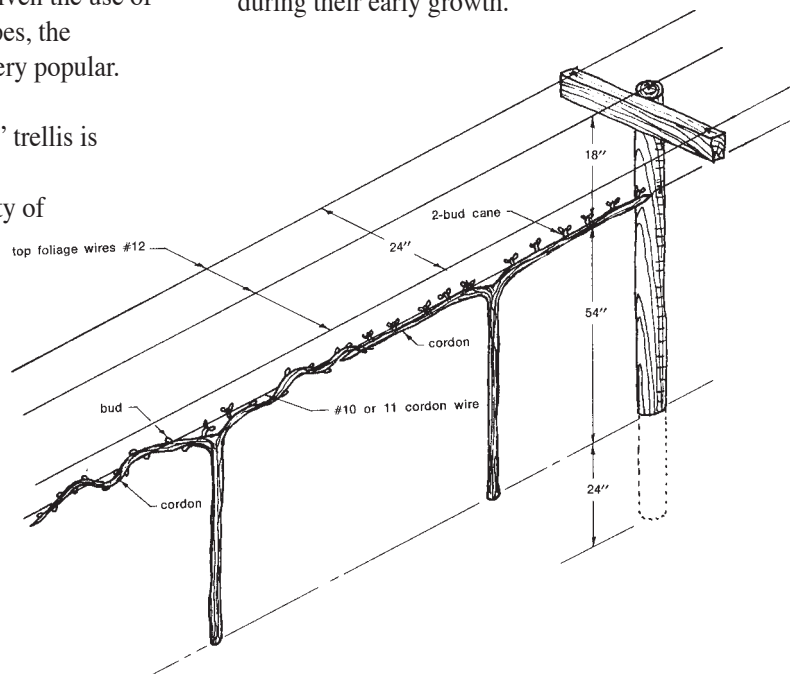

**Figure 3. “T” trellis, vines are bilateral cordon trained.**

## Geneva Double Curtain (GDC)

This training system was developed by researchers of the Geneva Agricultural Experiment Station, Cornell University, New York. In this system, the number of grape leaves that are effectively exposed to sunlight are considerably greater than in the single curtain training systems.

In the GDC system, the length of cordons per row is doubled. This exposes leaves on a greater number of shoots at their basal four to six nodes to sunlight. This is achieved with shoot positioning, a practice commonly adopted in New York but not in Washington state. For better adaptation to this system, the vines should be vigorous with a drooping shoot growth habit. However, cultivars not having these characteristics also have been trained to the GDC training system with economically significant yield increases.

This system requires a three-wire trellis, using two horizontal cordon-support wires and a lower single trunk support wire (Figure 4). The cordon support wires are placed 6 feet above the ground and  $3\frac{1}{2}$  to 4 feet apart.

For establishing vines for GDC, elongated trunks are passed behind and loosely secured to the lower

trunk-support wire with twine or plastic ties. As they grow, these are brought up and out to a cordon-support wire and tied to keep them in position. The cordons are formed by selecting shoots from the trunks going in opposite directions along the cordon support wire. The cordons on either direction should be held in contact with the cordon wire by wrapping them around support wire two to four wraps every 6 to 8 feet of cordon. Instead of wrapping around the wire, the cordons also can be tied with string or plastic ties.

The vines in the row usually are alternated to the left or right towards the cordon support wire to give the double curtain effect. After establishing the horizontal cordons, growers allow 10- to 12-foot equally spaced, preferably downward growing vertical arms per vine to develop. Selection of these arms is very important if shoot positioning is practiced, as the fruiting canes will originate from these arms. Selection of the right arms considerably cuts both labor and cost in future maintenance of cordons and for shoot positioning.

The cordon support wires should be of good quality steel. Usually a #10 or #11 wire is used for cordon support and a #11 or #12 wire for the lower wire for trunk support. Keep the cordon support wires taut. For efficient mechanical harvesting the fruiting cane area should be 5 to 5 1/2 feet above the ground.

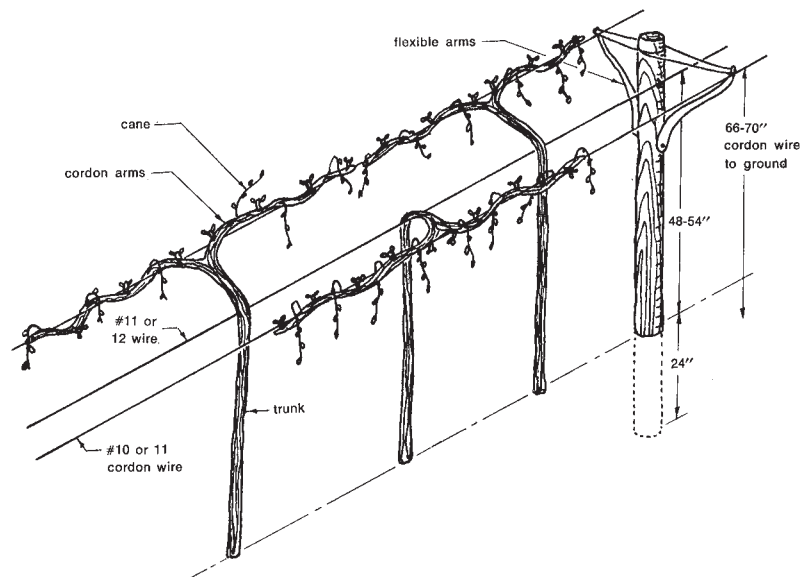
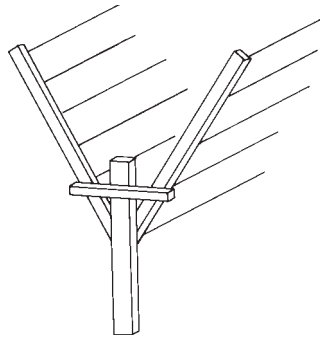

Figure 4. Double curtain trellis with bilateral cordon training.

# New Systems of Trellising

## Wye "Y" System

For establishing the trellis in the "Y" system, plant sturdy posts 3 feet in the ground and 3 to 4 feet aboveground. Nail and brace two posts to the vertical post at approximately a 45-degree angle, one on either side of the vertical post. A crossbar joining the vertical post and the two slanting posts provides strength to the framework. For training the vines, head them at about 3 feet from the ground level. This should give rise to branching of the main trunk. Bring the two best shoots at right angles to the row to form a "Y." These two shoots will form the arms of the "Y." From the tips of the "Y" a second head is established. From each of these heads two cordons are developed parallel to the row. A four-armed cordon (Quadrilateral) is thus established (Figure 5).



**Figure 5. Wye "Y" System.**

For best results with this system a distance of 4 feet between the wires is needed. Closer distances (3 feet) do not allow enough penetration of sunlight, resulting in shading. The wires should be 5 to 5½ feet from the ground level (Figure 5). It is more suited to vigorous cultivars like Sauvignon blanc. The system has been tried in California on a limited scale. More experience is needed with this system under Washington's growing conditions.

The chief disadvantage of this system is that with the mechanical harvesting machines available in Washington and California, fruit cannot be mechanically harvested. The higher cost of establishing a vineyard with this system is another factor.

## Gable Trellis

To construct a Gable trellis, plant lineposts (3 feet in the ground and 3 to 4 feet aboveground) in the row 30 feet apart. The overhead support is provided by placing poles from each linepost at a 45-degree angle. The overhead posts are not normally treated. The ends of the posts meet in the middle of the row 12 feet from ground level. When completed, the structure resembles a continuous "teepee" or angular overhead arbor.

The system uses 10 high tensile wires having a guaranteed breaking strength of 1,860 pounds; these are stapled to overhead bars. The wires in the gable system are tensioned at the end at 250 pounds when in use. Thus, for 10 wires a combined lateral pull of 2,500 pounds is needed at each anchor. The anchor posts, therefore, have to be very sturdy. For this reason, a 9-foot anchor post is needed. Five feet of this anchor is driven into the ground. The line and end posts in the gable system are custom driven. To each line post, overheads are attached with a pin made from smooth rebar. Both the line post and overhead are drilled using a bench drill (Figure 6). High labor costs make this a very expensive operation.

The advantage of the gable system over the bilateral cordon system is that it can expose more leaf area to the sun, thus increasing the photosynthetic capacity of grapevine. Since this trellis is an inverted "V" shape, shading is minimized both in the morning and afternoon hours.

The gable system has two main disadvantages:

- 1) it costs considerably more than the bilateral cordon system,
- 2) it does not lend itself to machine harvesting with the machines presently in use for grapes in Washington and California.

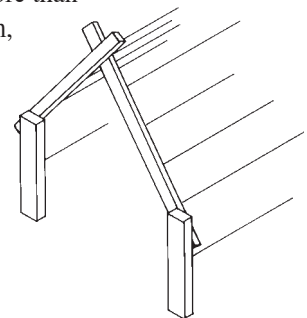

**Figure 6. Gable System.**

## Sloping Arm

To construct the “Sloping arm” trellis, drive a vertical post into the ground 3 feet with 3 feet remaining above the ground. Nail and brace a wooden arm at a 35-degree angle to the vertical post. The arm should project about 9 feet from the vertical post. Seven to nine wires are stapled 12 inches from each other.

Plant and train the vine along the vertical post. When it reaches the height of the sloping arm, the shoots are allowed to grow on the wires on the arm. The shoots completely cover the canopy when fully grown.

This system was introduced into the United States from South Africa, where very high yields have been obtained with this system due to greater exposure of the leaves to the sun. This system is more expensive to build than the two-wire vertical system. It is not possible to use mechanical harvesters with the sloping arm trellis. Because of the greater number of wires used, this system also is more expensive to maintain.

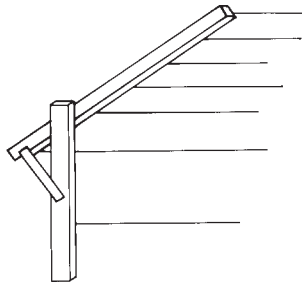
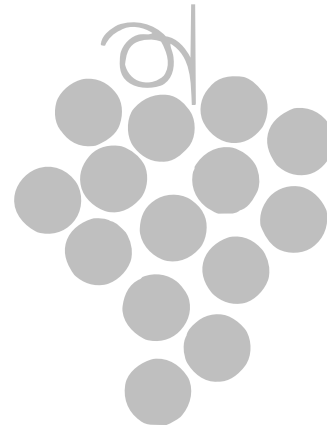

Figure 7. Sloping.

## Grape Arbors

Research and commercial plantings in certain parts of the world have demonstrated the importance of obtaining maximum exposure of grape foliage to light. Grape arbors facilitate this exposure. They can be constructed as double or multiple row arbors. Grapes are trained on cross wires from posts sufficiently high to facilitate operating equipment beneath the cross wires.

While high yields are obtained from such structures, the structures are expensive to erect and maintain. They also require a longer unproductive period between planting and commercial harvest—a delay of 2 or more years—while the vines mature and are trained out onto cross wires. Two other disadvantages are the difficulty in pruning and the lack of adaptability to present mechanical harvesting systems.



## End Posts and Anchorage

Whether grapes are to be grown on vertical trellises, “T” trellises, or double curtain trellises, secure anchorage of posts and wires is very important. Considerations are the height and weight of the vines, resistance to wind, the weight of the fruit, and stresses from mechanical harvesting. Many newer trellising systems are significantly increasing the tonnage of fruit to be supported.

Records of over 20 tons per acre (60 to 70 pounds of fruit per vine) have been experienced. Even a small give or shifting of the end posts can prevent mechanical harvesting or cause expensive delays. Various means have been taken to develop adequate anchorage. Some of these follow.



## "H" System

This system is commonly used in fencing (Figure. 8a). Two posts are set at least 6 feet apart with a horizontal cross member placed 12 inches from the top of the posts. A #9 wire is then doubled and wound between the base of the end post and the top of the inner post and tightened by twisting with an iron rod or a 1 x 2-inch piece of wood and locking behind the nearest post or cross member. This prevents the brace wire from unwinding and also prevents the tendency of the end post to loosen and lift out of the ground.

## Inverted "V"

This system is commonly used for high trellises and arbors (Figure 8b). It consists of a 9-foot-long end post, set at approximately a 60-degree angle rather than upright, with the base set about 3 feet into the ground. The top of the post is then tied with heavy wire to a large "deadman" placed 3 feet into the ground.

The system is strong and will resist considerable pull when properly constructed. Failures are experienced if the angle of the pull on the "deadman" is overly vertical. Placing the "deadman" out farther so the wire pulls at more of a 60-degree angle reduces the hazard of a lift.

A second weakness in this system is corrosion of the wire at the ground line. This problem can be reduced by utilizing a steel rod from the "deadman" to about a foot above the ground. The wire is then attached to the rod instead of directly to the "deadman." Covering the portion of the wire that is to be exposed to the soil with tar would prevent deterioration by rusting.

## Anchoring of Vertical End Posts

Increasing labor costs have caused growers to seek less expensive ways to anchor trellises. Instead of manually setting end posts on an angle, they can drive them vertically, as the remainder of the vineyard, and anchor them by a rod or heavy wire at a 45-degree angle (Figure 8c). Rock, concrete block, poured concrete, or a sizable metal object can be buried in the ground for anchoring. In rock-free soil, a 5-inch square of metal plate, cut diagonally and spread 1/2 inch at the corners and fixed to a metal rod (60 x 5/8 inches), can be turned into the soil at a 45-degree angle with a tractor power take-off, hydraulic motor, or heavy duty electric drill.

The disadvantage of this anchoring system is the vulnerability of the supporting wire to damage by vineyard equipment. To minimize this hazard, drive a marker post where the wire enters the soil.

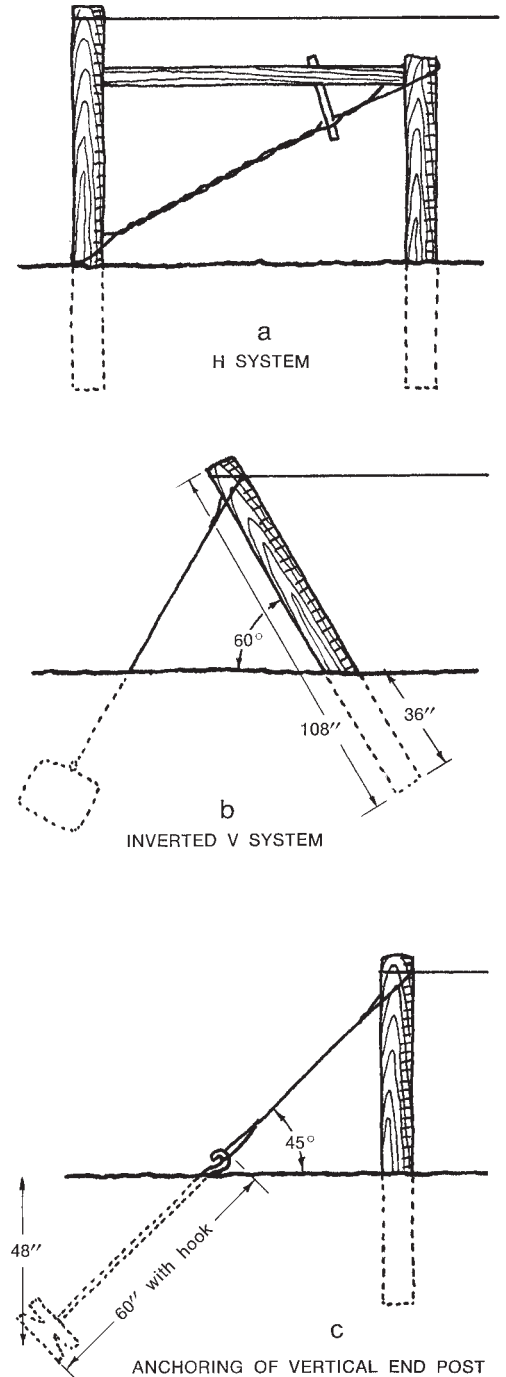

Figure 8. Anchoring systems.

# Spacing and Vineyard Layout

Several spacings are of concern when establishing a vineyard. Most obvious is the distance between rows and plants. Experience has shown that the distance allowed for turning equipment at the ends of the rows, spacing of posts and bracing wires, and length of rows can be equally as important.

at least 70 inches above ground level are necessary if double curtains 4 feet apart are used on rows spaced 9 feet apart. Double curtains 4 feet apart could be placed 5 1/2 feet above ground level if rows are spaced 10 feet apart. The decision involved in row spacing and trellis height is to be able to operate vineyard equipment either between the curtains of foliage or beneath them.

## Row Arrangement and Distance

Mechanical harvesting has emphasized the desirability of relatively long rows requiring few turns. Harvesters can accommodate some slight differences in topography but do not traverse steep slopes readily as they work up and down hillsides. Break long rows into about 600 feet between end posts. Greater distances create increased stress on end supports. Also, they tend to create more sag in the wire as the mechanical harvesters work.

## Plant and Post Spacing

The distance between plants determines the spacing of posts. In general, a distance of 18 to 21 feet between line posts reduces the sagging of wires to that which can be tolerated by mechanical harvesting devices. Distance between plants depends upon soil and plant vigor as well as training pattern. A distance of 8 feet is common with American-type grapes but may be reduced to as low as 6 feet on sandy, less fertile soils and expanded to 9 feet with vigorous European-type grapes on good soil.

## Headlands

Mechanical harvesters require a minimum turning radius of 20 feet. To prevent equipment from striking end posts and guide wires, more room is preferred. CAUTION: Where guide wires extend beyond the end posts, make certain the available headlands are measured to take this factor into account.

## Number of Plants per Acre

The number of plants per acre of ground varies according to planting distance, breaks, and head space. A guide to the number of plants required for the actual space planted follows:

## Row Spacing

Plant rows sufficiently close to make maximum use of the land but sufficiently wide to facilitate operation of equipment. In general, equipment requires 7 feet of free space. If an upright trellis is used, the distance between rows should be no less than 9 feet. When using a double curtain or "T" trellis, where row width is increased, the distance between rows may be increased to 10 feet.

Rows 9 feet apart can accommodate double curtains 3 feet apart placed 66 inches above ground level. However, accurate row spacing and trellis wires placed

Planting Distance	Number of Plants
6 x 9	807
7 x 9	691
8 x 9	605
6 x 10	726
7 x 10	622
8 x 10	545
9 x 10	484
6 x 11	660
7 x 11	566
8 x 11	495
9 x 11	440
10 x 11	396

# Training and Pruning Young Vines

As indicated under the discussion of systems of trellising, a number of training systems exist. Except where European-type grapes are to be taken down and covered with soil for winter protection, young vines are handled in much the same manner for the first 3 to 4 years.

## First Year—Year of Planting

After planting, cut back the young plant to the two best basal buds (Figure 9a). If the shoots grow vigorously that summer, train the strongest up a stake or a hemp string to the wire(s) on the trellis for developing a trunk. Pinch back the remaining growth to encourage maximum development of the selected shoot. However, the labor required the first year to train grapes is usually too excessive to be practical.

## Second Year—Year After Planting

During the dormant season, if a shoot was not selected and trained the previous summer, select the best positioned cane and tie it securely to the top wire (Figure 9b). If the cane is too short, tie the string just below the best top bud and extend to the top wire and secure. As shoots develop, retain the top two that are located 6 to 9 inches below the wire. These are to be trained each way along the wire for developing either cordons or short arms for bearing canes. Remove axillary shoots (new lateral shoots at base of leaf) that develop below this level while small. Summer pruning in July and later limits vine size and delays vine maturity.

If the cane growth is too small (less than 36 inches long and less than 1/4 inch in diameter) cut back all growth to two buds near the base of the best cane and train as described above.

With the Kniffin system, train one strong new shoot vertically to the upper wire, selecting laterals to train each way on both wires after the shoot has been tipped 6 inches below the top wire. Use a hemp or comparable strength string for training. However, tie

it either to a stake at the base of the vine or to the vine with a large nonslip loop to avoid girdling. Remove tendrils around the trunk, arms or canes that are to become permanent parts of the vine to prevent girdling.

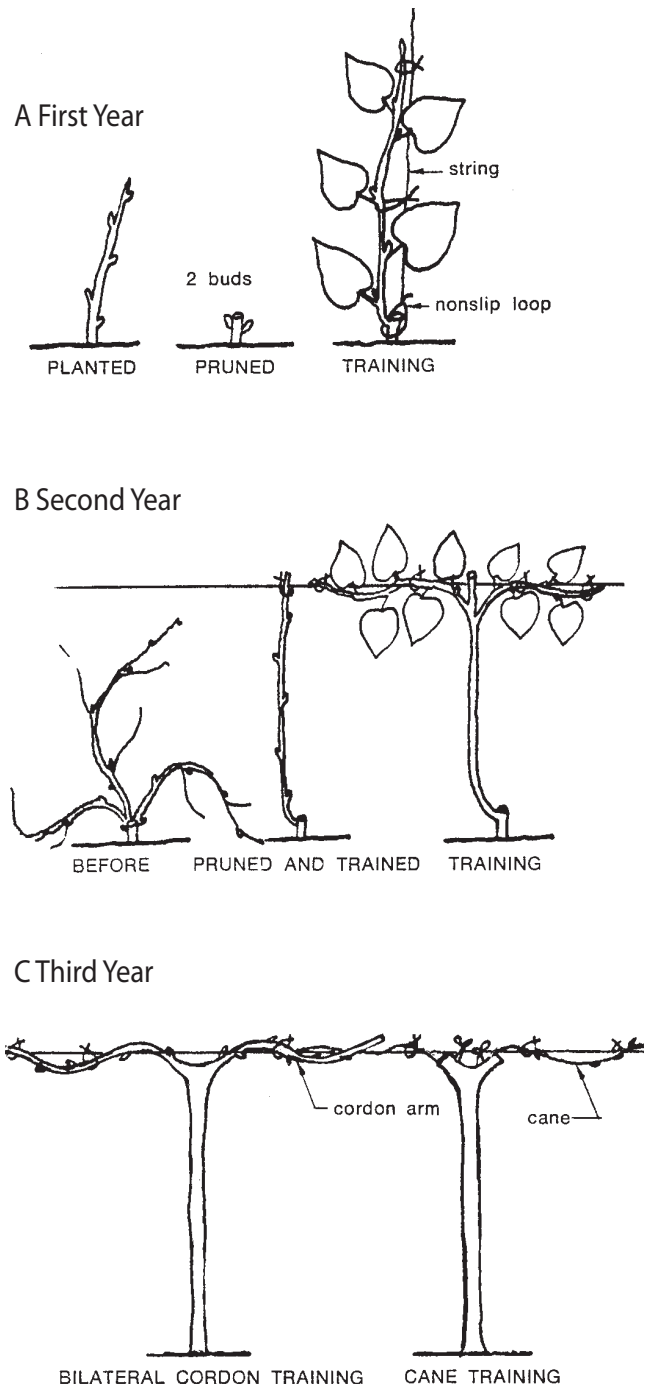

**Figure 9. Care of young vines the first three years in the vineyard.**

## Third Year

Continue the process of training the vines. Place the canes laterally in each direction to occupy the one- or two-wire system selected (Figure 9c).

Place canes trained for arms (cordons) bilaterally on a single wire system first over the windward (west or south) side of the wire and wrap at least one complete turn. Secure canes to the wire with loose ties at the point of first contact, at mid-point along the wire, and more tightly back of the end bud.

For the double curtain system, first place the canes for developing the cordons over the wire and wrap at least one complete turn and tie as for the single wire.

**CAUTION:** Because of the tendency of young vines to overfruit, do not retain over 20 to 30 buds on the most vigorous vines. Overproduction at this age can reduce potential production over the next 2 or 3 years.

If canes have not reached this stage of development, follow procedures described above for younger vines.

## Fourth Year and Later Years

If cordon training is desired, retain the canes that produced the crop the third year for future cordons. Cut the cane growth on the cordon alternately to one-bud and four-bud canes. Fill in vacant wire areas by extending canes from the end of the cordon. Remove other canes. One- or two- bud canes are retained on spur-pruned European varieties.

For long cane training on a single wire, leave two canes with two buds each for renewals at the base adjacent to the trunk and four 6- to 8-bud canes farther out for fruiting. Train two canes each in opposite directions. If a two-wire system is used, as with the Kniffin system (Figure 1), select two canes for the top wire and one or two for the bottom wire. Leave renewal buds at each level on the arm near the trunk.

# Training European Varieties for Winter Protection

## First Year—Year of Planting

After planting, cut back the young plant to the two best basal buds on two or three canes. Let shoot growth develop with no further training. Hill base of the plant with a hilling disk at the end of the growing season.

## Second Year—Year After Planting

Train one to three of the best canes upon the two-wire Kniffin type trellis with the canes distributed upright in a fanlike position and tie in place. Prune other canes originating at the ground level to one bud. At the end of the growing season, prune laterals one to five buds long on canes that developed the first year. Retain one or two additional canes that have developed. Leave no more than a total of 20 to 30 buds. Remove

all arms and canes from the wires, holding in place on the soil surface with notched 1 x 4-inch boards wedged under the lower wire. The canes and arms placed on the ground are covered with soil by driving on both sides of the row with a terracing disk. Remove wedging materials and proceed to the next row.

## Third Year and Thereafter

Remove most of the soil covering the vines with a grape hoe in late winter. Fork out arms and canes and shake free of soil. Tie up two to three arms and canes on the two-wire system in a fan position.

At the end of the growing season (November) and thereafter, prune and cover three to five canes and arms.

## Balance Pruning Mature Vine

To achieve maximum production from a vine, adjust pruning and fruiting according to vine vigor. The more vigorous the vine, the larger the number of buds which can be left to fruit. Weaker vines must be pruned more heavily to prevent overcropping and further weakening.

This relationship between vine vigor and the capacity to bear fruit and properly mature both the crop and shoots in the fall is called "balance pruning." It is based on the amount or weight of wood pruned from the vine. When growing the Concord variety, this balance between cane pruning, weight of the prunings, and yield has been established at the level of "50 + 10". This means that for the first pound of prunings removed, 50 buds are left on the vine. For each additional pound, 10 additional buds are retained. An example of its use with a vine producing 3.2 pounds of prunings follows:

1st pound .....	50 buds left
2nd pound .....	10 additional buds left
3rd pound .....	10 additional buds left
0.2 pound .....	2 additional buds left
3.2 total pounds .....	72 buds left

A proportionate amount of 50 buds is retained if the pruning weight is less than 1 pound.

Most other American varieties respond well at approximately the same pruning level as has been described for Concord. When growing European varieties, prune vines more severely according to the vigor. Satisfactory yields and vine growth have been obtained by balance pruning at a bud level of 10 + 10 in California.

## Summary

Different types of trellis structures for supporting vines vary in type of material used and the relative exposure of leaves to sun. The most common in cold climates is the simple one- or two-wire vertical type trellis. Due to the use of fewer wires and simplicity of design, it is the least expensive. The newer systems, especially those using metal stakes and "T" type trellis design, are becoming popular because they offer distinct advantages in machine harvesting.

The new trellises discussed in this bulletin have the advantage of increased yield and better exposure of leaves to sunlight, but they are more expensive to build. They have the potential of considerable increase in yield but have not been tried sufficiently in the colder climates. Consider all factors discussed in this bulletin before attempting to establish the vineyard with the new systems.

In the Pacific Northwest where low winter temperatures are common, keep yields at moderate levels to minimize winter damage. Very high yields obtained with some of the newer systems of training and trellising are a risky proposition in the Pacific Northwest.



---

## Glossary of Terms

A number of terms are used to describe portions or locations on grape plants. Some of them are used in the discussion of the trellising and training of grapes. The following definitions may be helpful.

TRUNK:	Permanent aboveground stem of the vine.
ARMS:	Major short branches of the trunk from which canes develop.
CORDON:	A long arm, usually trained along a wire, from which canes develop.
CANE:	A matured shoot after leaf fall.
SPUR:	A cane pruned back to one, two, or three nodes.
SHOOT:	New green growth with leaves, developing from a bud of a cane or spur.
LATERAL:	A branch of a shoot.
NODE:	The thickened portion of the shoot or cane where the leaf and its compound bud are located.
INTERNODE:	The portion of the shoot or cane between two nodes.
BUD:	A compound bud or eye containing the primary, secondary, and tertiary buds located in the axil or each leaf.
TENDRIL:	A long, slender, curled structure borne at some of the nodes of a shoot that can firmly attach the shoot to other shoots and the trellis system.

M. Ahmedullah, Ph.D.,  
Washington State University  
horticulturist, WSU Pullman.

College of Agricultural, Human, and Natural  
Resource Sciences

WSU Extension bulletins contain material written and produced for public distribution. You may reprint written material, provided you do not use it to endorse a commercial product. Alternate formats of our educational materials are available upon request for persons with disabilities.

Please contact the Information Department,  
College of Agricultural, Human, and Natural  
Resource Sciences, Washington State University  
for more information.

Issued by Washington State University Extension and the U.S. Department of Agriculture in furtherance of the Acts of May 8 and June 30, 1914.

Extension programs and policies are consistent with federal and state laws and regulations on nondiscrimination regarding race, sex, religion, age, color, creed, national or ethnic origin; physical, mental, or sensory disability; marital status, sexual orientation, and status as a Vietnam-era or disabled veteran. Evidence of noncompliance may be reported through your local Extension office. Trade names have been used to simplify information; no endorsement is intended.

Reprinted March 1996.

Subject code 234. B

EB0637